

Apollo™

Model 610A

Truck Probe Sampling System

- Core and compartment styles.
- Suitable for small to medium elevator applications.
- Supplied complete with all hydraulic, vacuum and electric components required.
- Short and long distance vacuum systems.
- Dual joystick operator control station.
- Complete line of accessory items are available for all of our Truck Probe Sampling Systems.

The Model 610A is the smaller of the Apollo truck probe offerings. It is ideal for use with all whole grains in low- to mid-volume applications. Ruggedly built, it will provide your operators with years of use at an affordable price.

The Model 610A has a proven track record in low- to mid-volume applications. County elevator, small terminal and on-farm use are likely applications for this model.

Like all Apollo systems the Model 610A is supplied complete with a powerful hydraulic system, vacuum system and complete control system for easy installation and use.



GAMET MANUFACTURING, INC.
7400 Boone Avenue North · Brooklyn Park, MN USA 55428
info@gametmfg.com · www.gametmfg.com
Toll Free 888-647-5475

Apollo™ Model 610A

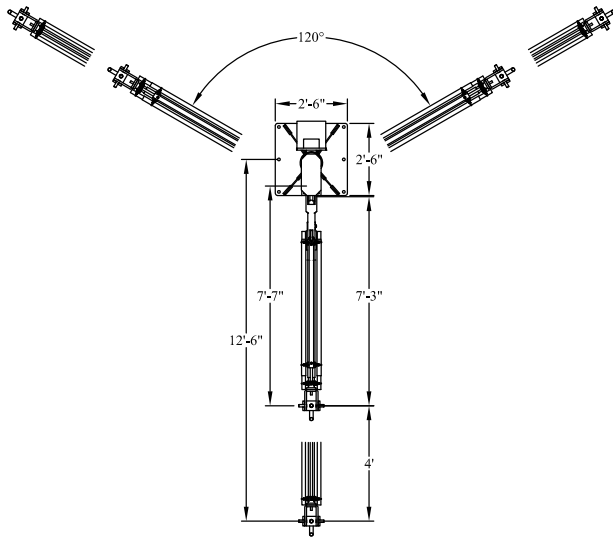

System Specifications

- Base: 30" x 30"*
- Height: 12' 6"*
- Rotation: 240°*
- Reach: 11' 3"*
- Core Probe Length: 6'*
- Hydraulic Pump: 2 HP, 3.6 GPM, 1,500 PSI
- System Voltage: 1/60/220*

* Other Options Available

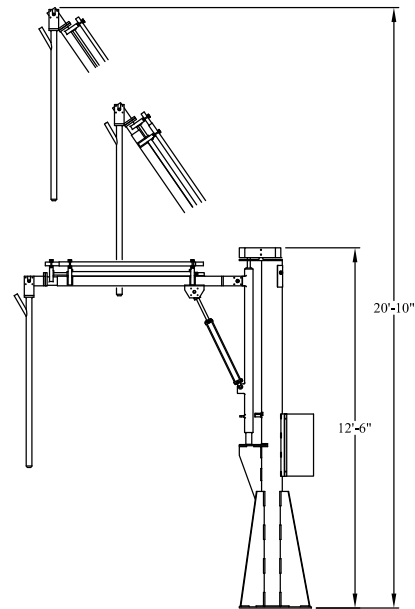

Vacuum System Options

Standard Vacuum System: Supplied with a separate vacuum and clean air supply motor. Suitable for conveying product up to 120'.

Dual Vacuum System: Supplied with (2) separate vacuums and (1) clean air supply motor. Suitable for conveying product up to 250'.

Positive Displacement Pump System: Supplied with a separate vacuum pump and clean air supply motor. Suitable for conveying product in excess of 250'.

Available Accessories

Cyclone Style Collection System
Gravity Divider
Excess Sample Return Systems
One Way Scale Ticket Conveying System
Bi-Directional Scale Ticket Return System

Video Monitoring Equipment (CCTV)
Traffic Control Lights
Audio Intercom System
Signal Alarm

Tubing Support / Structure System: Engineered tubing support system provides a mounting mechanism for sample conveying tubing, electric conduit and a variety of truck probe system accessories. These easy to install systems are designed so no welding and special tooling is required.



GAMET MANUFACTURING, INC.
7400 Boone Avenue North · Brooklyn Park, MN USA 55428
info@gametmfg.com · www.gametmfg.com
Toll Free 888-647-5475