

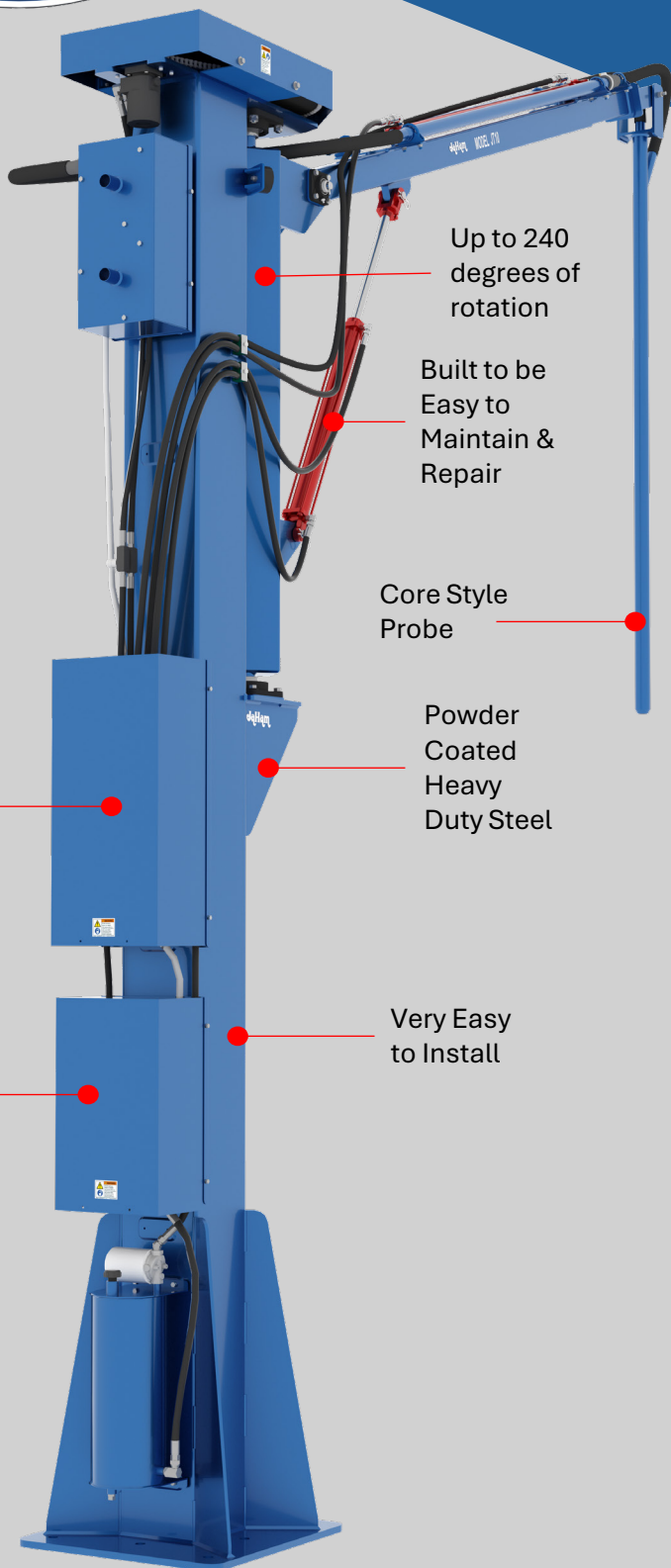

Model JT10

JaHamTM

Truck Probe
Sampling System



Up to 240 degrees of rotation

Built to be Easy to Maintain & Repair

Core Style Probe

Powder Coated Heavy Duty Steel

Very Easy to Install

Certified Controls Available

2 HP Motor

Handheld Joystick Controls

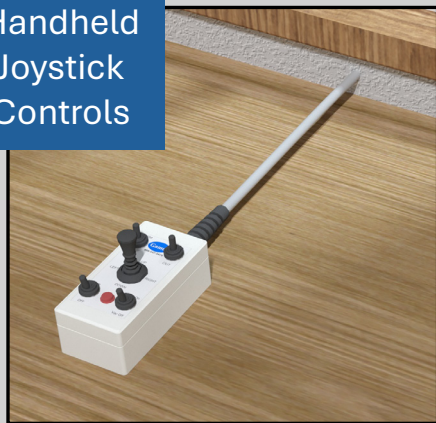

Multiple Vacuum Options

- Designed for Low to Medium Volume Applications
- Supplied With all Hydraulic, Vacuum, & Electric Components
- Line of Accessory Items Available to Create a Comprehensive System

Designed to Provide Years of Reliability

Gamet Manufacturing Inc.

Email: info@gametmfg.com

Toll Free: 888-647-5475

www.gametmfg.com

Mailing Address:

7400 Boone Ave N

Brooklyn Park, MN 55428

Vacuum System Options

Standard Vacuum System

Supplied with a separate vacuum & clean air supply motor. Suitable for conveying product up to 120'.

Clean Air Supply

Pull Vac

Back of Probe

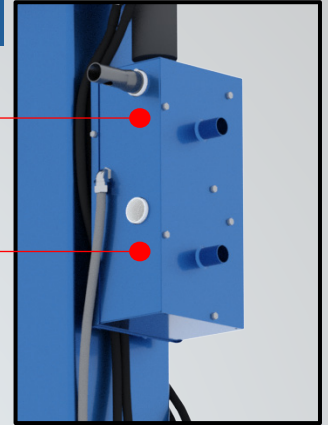

Dual Vacuum System

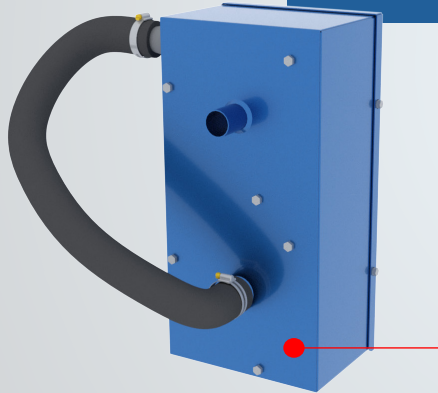

Dual Pull Vac

Supplied with (2) separate vacuums & (1) clean air supply motor. Suitable for conveying product up to 250'.

Positive Displacement Pump System

Supplied with a separate vacuum pump & clean air supply motor. Suitable for conveying product in excess of 250'.



System Accessories

Traffic Lights

- Modular Design for many possible configurations.
- Controls can be incorporated into the probe controller.



Bridge & Support Structure

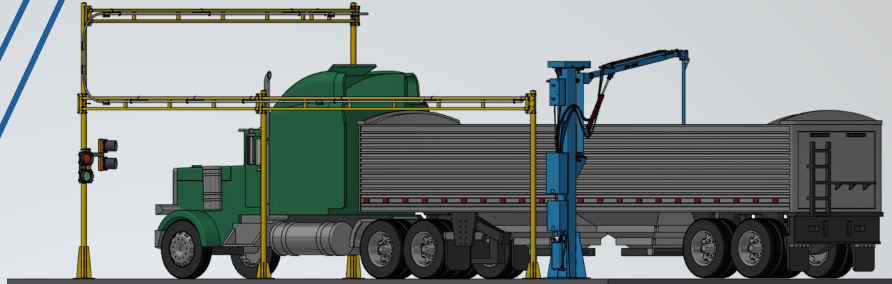

Grain Return System

This complete excess sample return system allows elevator personal to transport excess grain samples back to the top of the sample probe.

(See brochure for more info)

- Modular design to fit site needs
- Powder coated steel construction
(See brochure for more info)

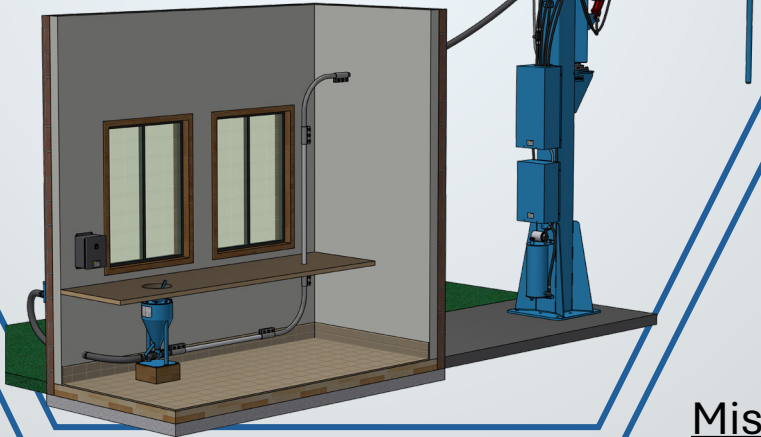

Miscellaneous

Camera System

For applications where a truck probe operator doesn't have a clear vision into the probing area.

(Camera, Monitor, & other components provided. See brochure for more info)

- A signal alarm can be attached to the truck probe, controlled by the probe controller.
- Cyclone Style Collection System can be used for difficult to convey commodities and noise reduction in the office/lab.



Truck Probe Dimensions

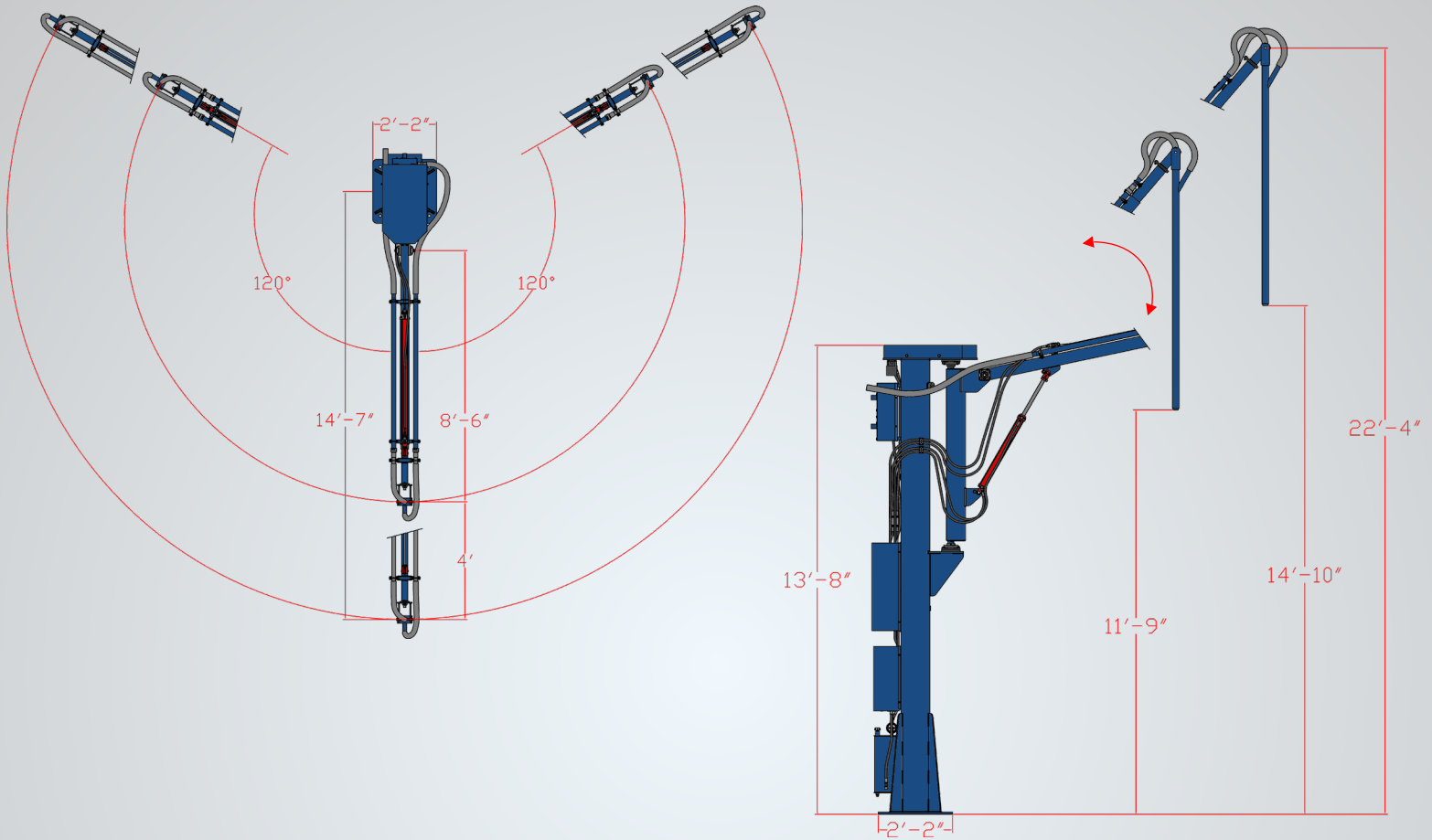

System Specifications

Base	Height	Rotation	Reach	Probe Length	Hydraulic Pump	Voltage
26" x 26"	13' 8"	180° or 240°	8' 6" - 12' 6"	6', 7' or 8'	2HP, 3.6 GPM, & 1,500 PSI	1 Phase or 3 Phase

Our Engineers and Sales Team are available to review your specific needs and help you select the proper size equipment and accessories for your application.

Proudly Made in the USA 